



**REPUBLIC OF KENYA
THE NATIONAL TREASURY AND PLANNING
TREASURY BUILDING, HARAMBEE AVENUE
PO BOX 30007 – 00100, NAIROBI, KENYA**

FRAMEWORK TENDER

FOR

**PROCUREMENT OF CO-LOCATION AND SUPPORT
SERVICES FOR E-CITIZEN PLATFORM**

TENDER NO. TNT/028/2019-2020

CLOSING DATE 25th February, 2020 AT 11.00 A.M.

INVITATION TO TENDER



REPUBLIC OF KENYA THE NATIONAL TREASURY AND PLANNING

PROCUREMENT OF CO-LOCATION AND SUPPORT SERVICES FOR E-CITIZEN PLATFORM FOR A PERIOD OF THREE (3) YEARS TENDER NO. TNT/028/2019-2020

The National Treasury invites Tenders from eligible candidates for Procurement of Co-location Services for E-citizen Platform for a period of **Three (3 No,) Years**.

A complete set of Tender Documents may be downloaded by interested candidates **Free of Charge** at <http://treasury.go.ke> or www.tender.go.ke and those who have downloaded the document from the website **must forward their particulars immediately for recording and any further clarifications and addenda to procurement@treasury.go.ke**.

All Bid Documents must be serialized / paginated.

A pre-bid conference will be held with the interested Service Providers on 18th February, 2020 at 10.00 a.m. on the 6th Floor Conference Room 603, Treasury Building, Harambee Avenue, Nairobi.

Completed Tender Documents (both “Original” and “Copy”), enclosed in plain sealed envelope, marked with the Tender Number shall be addressed to: -

**The Principal Secretary,
The National Treasury,
PO Box 30007 – 00100,
Nairobi, Kenya**

Should be deposited in the Tender Box provided at the Treasury Building, 6th Floor, Harambee Avenue, Nairobi, so as to be received on or **before 25th February, 2020 at 11.00 a.m.**

Bids shall be accompanied by a Bid Security of **Kenya Shillings Five Hundred Thousand Only (Kshs. 500,000.00)** from a reputable financial institution valid for 30 days beyond Tender Validity.

Tenders will be opened immediately after the closing date and time in the presence of candidates or their representatives who choose to attend at the Conference Room on 6th Floor, Treasury Building, Harambee Avenue **on 25th February, 2020 at 11.00 a.m.**

**HEAD, SUPPLY CHAIN MANAGEMENT SERVICES.
FOR: PRINCIPAL SECRETARY / NATIONAL TREASURY**

Table of Contents

SECTION I	INVITATION TO TENDER	2
SECTION II	- INSTRUCTIONS TO TENDERERS	5
2.1	Eligible Tenderers	5
2.2	Cost of Tendering.....	5
2.3	Contents of Tender Documents	5
2.4	Clarification of tender Documents	6
2.5	Amendment of tender Documents.....	6
2.6	Language of Tenders	6
2.7.	Documents Comprising the Tender	7
2.8.	Form of Tender	7
2.9.	Tender Prices	7
2.10.	Tender Currencies	7
2.11.	Tenderers Eligibility and Qualifications	7
2.12.	Tender Security.....	8
2.13.	Validity of Tenders.....	8
2.14.	Format and Signing of Tenders	9
2.15	Sealing and Marking of Tenders.....	9
2.16.	Deadline for Submission of Tenders.....	9
2.17.	Modification and Withdrawal of Tenders.....	10
2.18.	Opening of Tenders	10
2.19	Clarification of Tenders.....	10
2.20	Preliminary Examination and Responsiveness.....	11
2.21.	Conversion to single currency	11
2.22.	Evaluation and Comparison of Tenders	11
2.23.	Contacting the Procuring entity	12
2.24	Post-qualification.....	12
2.25	Award Criteria.....	13
2.26.	Procuring entity's right to accept or reject any or all tenders.....	13
2.27	Notification of Award.....	13
2.29	Signing of Contract.....	14
2.30	Performance Security.....	14
2.31	Corrupt or Fraudulent Practices	14
SECTION III	GENERAL CONDITIONS OF CONTRACT	21
3.1	Definitions.....	21
3.2	Application	21
3.3	Country of Origin.....	21
3.4	Standards.....	21
3.5	Use of Contract Documents and Information.....	21
3.6	Patent Rights.....	22
3.7	Performance Security.....	22
3.8	Inspection and Tests.....	22
3.9	Packing.....	23
3.10	Delivery and Documents	23
3.11	Insurance	23
3.12	Payment.....	23
3.13	Prices	23

3.14	Assignment.....	24
3.15	Subcontracts.....	24
3.16	Termination for default	24
3.17	Liquidated Damages.....	24
3.18	Resolution of Disputes	24
3.19	Language and Law.....	25
3.20	Force Majeure	25
SECTION IV - SPECIAL CONDITIONS OF CONTRACT		26
SECTION V - SCHEDULE OF REQUIREMENTS		28
SECTION VI STANDARD FORMS		32
7.1	FORM OF TENDER	33
7.2	CONTRACT FORM	34
7.3	CONFIDENTIAL BUSINESS QUESTIONNAIRE FORM	35
7.4	PRICE SCHEDULE FORM	36
7.5	TENDER SECURITY FORM	37
7.6	TENDER SECURING DECLARATION	38
7.7	PERFORMANCE SECURITY FORM.....	39
7.8	MANUFACTURERS AUTHORIZATION FORM.....	40
7.9	LETTER OF ACCEPTANCE/NOTIFICATION OF AWARD	41
7.10	FORM RB 1.....	42

SECTION II- INSTRUCTIONS TO TENDERERS

2.1 Eligible Tenderers

- 2.1.1 This invitation for tenders is open to all tenderers eligible as described in the Appendix to Instructions to Tenderers. Successful tenderers shall be contracted for the stipulated duration from the date of commencement (hereinafter referred to as the term) specified in the schedule of requirements.
- 2.1.2 The procuring entity's employees, committee members, board members and their relative (spouse and children) are not eligible to participate in the tender.
- 2.1.3 Tenderers shall provide the qualification statement that the tenderer (including all members of a joint venture and subcontractors), is not associated, or have been associated in the past, directly or indirectly, with the firm or any of its officials which have been engaged by the procuring entity to provide consulting services for the preparation of the design specifications and other documents to be used for the purpose of this invitation to tender.
- 2.1.4 Tenderers involved in corrupt or fraudulent practices or debarred from participating in public procurement shall not be eligible.

2.2 Cost of Tendering

- 2.2.1 The Tenderer shall bear all costs associated with the preparation and submission of its tender, and the procuring entity, will in no case be responsible or liable for those costs, regardless of the conduct or outcome of the tendering process
- 2.2.2 The price to be charged for the tender document shall not exceed Kshs. 1,000/=
- 2.2.3 The procuring entity shall allow the tenderer to review the tender document free of charge before purchase.

2.3 Contents of Tender Documents

- 2.3.1 The tender documents comprise the documents listed below and addenda issued in accordance with clause 2.7 of these instructions to tenderers.
 - (i) Instructions to tenderers
 - (ii) General Conditions of Contract
 - (iii) Special Conditions of Contract
 - (iv) Schedule of particulars of tender
 - (v) Form of Tender
 - (vi) Price Schedules
 - (vii) Contract Form
 - (viii) Confidential Business Questionnaire Form

- (ix) Tender security Form
- (x) Performance security Form
- (xi) Authorization Form
- (xii) Declaration form
- (xiii) Request for Review Form
- (xiv) A Securing Declaration Form

2.3.2 The Tenderer is expected to examine all instructions, forms, terms and particulars in the tender documents. Failure to furnish all information required by the tender documents or to submit a tender not substantially responsive to the tender documents in every respect will be at the tenderers risk and may result in the rejection of its tender.

2.4 Clarification of tender Documents

2.4.1 A prospective tenderer making inquiry on the tender documents may notify the Procuring entity by post, fax or by email at the procuring entity's address indicated in the Invitation to Tender. The Procuring entity will respond in writing to any request for clarification of the tender documents, which it receives no later than seven (7) days prior to the deadline for the submission of tenders, prescribed by the procuring entity. Written copies of the Procuring entities response (including an explanation of the query but without identifying the source of inquiry) will be sent to all candidates who have received the tender documents.

2.4.2 The procuring entity's employees, committee members, board members and their relative (spouse and children) are not eligible to participate in the tender.

2.5 Amendment of tender Documents

2.5.1 At any time prior to the deadline for submission of tenders, the Procuring entity, for any reason, whether at its own initiative or in response to a clarification requested by a prospective tenderer, may modify the tender documents by issuing an addendum.

2.5.2 All prospective tenderers who have obtained the tender documents will be notified of the amendment by post, fax or email and such amendment will be binding on them.

2.5.3 In order to allow prospective tenderers reasonable time in which to take the amendment into account in preparing their tenders, the Procuring entity, at its discretion, may extend the deadline for the submission of tenders.

2.6 Language of Tenders

2.6.1 The tender prepared by the tenderer, as well as all correspondence and documents relating to the tender exchanged by the tenderer and the Procuring entity, shall be written in English language. Any printed literature furnished by the tenderer may be written in another language provided they are accompanied by an accurate English translation of the relevant

passages in which case, for purposes of interpretation of the tender, the English translation shall govern.

2.7. Documents Comprising the Tender

2.7.1 The tender prepared by the tenderer shall comprise the following components:

- (a) a Tender Form and a Price Schedule completed in accordance with paragraph 2.8, 2.9 and 2.10 below
- (b) documentary evidence established in accordance with paragraph 2.12 that the tenderer is eligible to tender and is qualified to perform the contract if its tender is accepted;
- (c) tender security furnished in accordance with paragraph 2.12

2.8. Form of Tender

2.8.1 The tenderer shall complete the Form of Tender and the Price Schedules furnished in the tender documents, indicating the particulars of the tender.

2.9. Tender Prices

2.9.1 The tenderer shall indicate on the Price Schedules the unit prices and total tender price of the particular of tender under the contract.

2.9.2 Prices indicated on the Price Schedule shall be the amounts to be paid by the tenderer to the procuring entity for the particulars of the tender under the contract.

2.9.3 Prices quoted by the tenderer shall remain fixed during the term of the contract unless otherwise agreed by the parties. A tender submitted with an adjustable price quotation will be treated as non-responsive and will be rejected, pursuant to paragraph 2.20.5

2.10. Tender Currencies

2.10.1 Prices shall be quoted in Kenya Shillings unless otherwise stated in the appendix.

2.11. Tenderers Eligibility and Qualifications

2.11.1 Pursuant to paragraph 2.1.1 and 2.1.2 the tenderer shall furnish, as part of its tender, documents establishing the tenderers eligibility to tender and its qualifications to perform the contract if it's tender is accepted.

2.11.2 The documentary evidence of the tenderer's qualifications to perform the contract if its tender is accepted shall establish to the Procuring entity's satisfaction that the tenderer has the financial and technical capability necessary to perform the contract.

2.12. Tender Security

- 2.12.1 The tenderer shall furnish, as part of its tender, a tender security for the amount and form specified in the Appendix to Instructions to Tenderers.
- 2.12.2 The tender security shall be in the amount not exceeding 2 per cent of the tender price.
- 2.12.3 The tender security is required to protect the Procuring entity against the risk of Tenderer's conduct which would warrant the security's forfeiture, pursuant to paragraph 2.12.7
- 2.12.4 The tender security shall be denominated in Kenya Shillings or in another freely convertible currency, and shall be in the form of
- a) Cash.
 - b) A bank guarantee.
 - c) Letter of credit.
 - d) Such insurance guarantee approved by the Public Procurement Regulatory Authority
- 2.12.5 Any tender not secured in accordance with paragraph 2.12.1. and 2.12.3 will be rejected by the Procuring entity as non-responsive, pursuant to paragraph 2.20.5
- 2.12.6 Unsuccessful Tenderer's tender security will be discharged or returned as promptly as possible but not later than thirty (30) days after the expiration of the period of tender validity
- 2.12.7 The successful Tenderer's tender security will be discharged upon the tenderer signing the contract, pursuant to paragraph 2.29, and furnishing the performance security, pursuant to paragraph 2.30
- 2.12.8 The tender security may be forfeited:
- (a) if a tenderer withdraws its tender during the period of tender validity
 - (b) in the case of a successful tenderer, if the tenderer fails:
 - (i) to sign the contract in accordance with paragraph 2.29 or
 - (ii) to furnish performance security in accordance with paragraph 2.30
 - (c) If the tenderer rejects a correction of an arithmetic error in the tender.

2.13. Validity of Tenders

- 2.13.1 Tenders shall remain valid for 150 days after date of tender opening pursuant to paragraph 2.18. A tender valid for a shorter period shall be rejected by the Procuring entity as non-responsive.
- 2.13.2 In exceptional circumstances, the Procuring entity may solicit the Tenderer's consent to an extension of the period of validity. The request and the responses thereto shall be made in writing. The tender security provided under paragraph 2.12 shall also be suitably extended. A tenderer granting the request will not be required nor permitted to modify its tender.

2.14. Format and Signing of Tenders

- 2.14.1 The tenderer shall prepare an **Original** and **Five (5) copies** of the tender, clearly marking each “ORIGINAL TENDER” and “COPY OF TENDER,” as appropriate. In the event of any discrepancy between them, the original shall govern.
- 2.14.2 The original and all copies of the tender shall be typed or written in indelible ink and shall be signed by the tenderer or a person or persons duly authorized to bind the tenderer to the contract. All pages of the tender, except for un-amended printed literature, shall be initialed by the person or persons signing the tender.
- 2.14.3 The tender shall have no interlineations, erasures, or overwriting except as necessary to correct errors made by the tenderer, in which case such corrections shall be initialed by the person or persons signing the tender.

2.15 Sealing and Marking of Tenders

- 2.15.1 The tenderer shall seal the original and the three copies of the tender in separate envelopes, duly marking the envelopes as “**ORIGINAL TENDER**” and “**COPY OF TENDER**”. The envelopes shall then be sealed in an outer envelope.

- 2.15.2 The inner and outer envelopes shall be addressed to

**The Principal Secretary,
The National Treasury
P.O. Box 30007
Nairobi**

bear tender number and name in the Invitation to Tender and the words, “**DO NOT OPEN BEFORE 25th February, 2020 at 11.00 a.m.**”

- 2.15.3 The inner envelopes shall also indicate the name and address of the tenderer to enable the tender to be returned unopened in case it is declared “late”.
- 2.15.4 If the outer envelope is not sealed and marked as required by paragraph 2.15.2, the Procuring entity will assume no responsibility for the tender’s misplacement or premature opening.

2.16. Deadline for Submission of Tenders

- 2.16.1 Tenders must be received by the Procuring entity at the address specified under paragraph 2.15.2 no later than **25th February, 2020 at 11.00 a.m.**
- 2.16.2 The Procuring entity may, at its discretion, extend this deadline for the submission of tenders by amending the tender documents in accordance with paragraph 2.5.3 in which case all rights and obligations of the Procuring entity and candidates previously subject to the deadline will thereafter be subject to the deadline as extended.

2.16.3 Bulky tenders which will not fit in the tender box shall be received by the procuring entity as provided for in the appendix.

2.17. Modification and Withdrawal of Tenders

2.17.1 The tenderer may modify or withdraw its tender after the tender's submission, provided that written notice of the modification, including substitution or withdrawal of the tenders, is received by the Procuring entity prior to the deadline prescribed for submission of tenders.

2.17.2 The tenderer's modification or withdrawal notice shall be prepared, sealed, marked and dispatched in accordance with the provisions of paragraph 2.15. a withdrawal notice may also be sent by fax or email but followed by a signed confirmation copy, postmarked not later than the deadline for submission of tenders.

2.17.3 No tender may be modified after the deadline for submission of tenders.

2.17.4 No tender may be withdrawn in the interval between the deadline for submission of tenders and the expiration of the period of tender validity. Withdrawal of a tender during this interval may result in the Tenderer's forfeiture of its tender security, pursuant to paragraph 2.12.7.

2.18. Opening of Tenders

2.18.1 The Procuring entity will open all tenders in the presence of tenderers' representatives who choose to attend, at **25th February, 2020 at 11.00 a.m.** and in the location specified in the Invitation of tender. The tenderers' representatives who are present shall sign a register evidencing their attendance

2.18.2 The tender's names, tender modifications or withdrawals, tender prices, discounts, and the presence or absence of requisite tender security and such other details as the Procuring entity, at its discretion, may consider appropriate, will be announced at the opening.

2.18.3 The Procuring entity will prepare minutes of the tender opening, which will be submitted to tenderers that signed the tender opening register and will have made the request.

2.19 Clarification of Tenders

2.19.1 To assist in the examination, evaluation and comparison of tenders the Procuring entity may, at its discretion, ask the tenderer for a clarification of its tender. The request for clarification and the response shall be in writing, and no change in the prices or substance of the tender shall be sought, offered, or permitted.

2.19.2 Any effort by the tenderer to influence the Procuring entity in the Procuring entity's tender evaluation, tender comparison or contract award decisions may result in the rejection of the tenderers' tender.

2.20 Preliminary Examination and Responsiveness

- 2.20.1 The Procuring entity will examine the tenders to determine whether they are complete, whether any computational errors have been made, whether required sureties have been furnished, whether the documents have been properly signed, and whether the tenders are generally in order.
- 2.20.2 The tender sum as submitted and read out during the tender opening shall be absolute and final and shall not be the subject of correction, adjustment or amendment in any way by any person or entity.
- 2.20.3 The Procuring entity may waive any minor informality or non-conformity or irregularity in a tender which does not constitute a material deviation provided such waiver does not prejudice or affect the relative ranking of any tenderer.
- 2.20.4 Prior to the detailed evaluation, pursuant to paragraph 2.20, the Procuring entity will determine the substantial responsiveness of each tender to the tender documents. For purposes of these paragraphs, a substantially responsive tender is one which conforms to all the terms and conditions of the tender documents without material deviations the Procuring entity's determination of a tender's responsiveness is to be based on the contents of the tender itself without recourse to extrinsic evidence.
- 2.20.5 If a tender is not substantially responsive, it will be rejected by the procuring entity and may not subsequently be made responsive by the tenderer by correction of the nonconformity.

2.21. Conversion to single currency

- 2.21.1 Where other currencies are used, the Procuring entity will convert those currencies to Kenya Shillings using the selling exchange rate on the date of tender closing provided by the Central Bank of Kenya.

2.22. Evaluation and Comparison of Tenders

- 2.22.1 The Procuring entity will evaluate and compare the tenders which have been determined to be substantially responsive, pursuant to paragraph 2.20
- 2.22.2 The Procuring entity's evaluation of a tender will take into account, in addition to the tender price, the following factors, in the manner and to the extent indicated in paragraph 2.22.3.
- (a) Operational plan proposed in the tender;
 - (b) Deviations in payment schedule from that specified in the Special Conditions of Contract
- 2.22.3 Pursuant to paragraph 2.22.2. the following evaluation methods will be applied.

- (a) Operational Plan

(i) The Procuring entity requires that the services under the Invitation for Tenders shall be performed at the time Specified in the Schedule of Requirements. Tenderers offering to perform longer than the procuring entity's required delivery time will be treated as non-responsive and rejected.

(b) Deviation in payment schedule

(i) Tenderers shall state their tender price for the payment on schedule outlined in the special conditions of contract. Tenders will be evaluated on the basis of this base price.

Tenderers are, however, permitted to state an alternative payment schedule and indicate the reduction in tender price they wish to offer for such alternative payment schedule. The Procuring entity may consider the alternative payment schedule offered by the selected tenderer.

2.22.4 Preference where allowed in the evaluation of tenders shall not exceed 15%.

2.22.5 The evaluation committee shall evaluate the tenders within 30 days from the date of opening the tender.

2.23. Contacting the Procuring entity

2.23.1 Subject to paragraph 2.19 no tenderer shall contact the Procuring entity on any matter relating to its tender, from the time of the tender opening to the time the contract is awarded.

2.23.2 Any effort by a tenderer to influence the Procuring entity in its decisions on tender evaluation, tender comparison, or contract award may result in the rejection of the Tenderers' tender.

2.24 Post-qualification

2.24.1 The Procuring entity will verify and determine to its satisfaction whether the tenderer that is selected as having submitted the lowest evaluated responsive tender is qualified to perform the contract satisfactorily.

2.24.2 The determination will take into account the tenderer financial and technical capabilities. It will be based upon an examination of the documentary evidence of the tenderers qualifications submitted by the tenderer, pursuant to paragraph 2.11.2, as well as such other information as the Procuring entity deems necessary and appropriate

2.24.3 An affirmative determination will be a prerequisite for award of the contract to the tenderer. A negative determination will result in rejection of the Tenderer's tender, in which event the Procuring entity will proceed to the next lowest evaluated tender to make a similar determination of that Tenderer's capabilities to perform satisfactorily.

2.25 Award Criteria

2.25.1 Subject to paragraph 2.29 the Procuring entity will award the contract to the successful tenderer whose tender has been determined to be substantially responsive and qualified to perform the contract satisfactorily.

2.25.2 To qualify for contract awards, the tenderer shall have the following:-

- (a) Necessary qualifications, capability experience, services, equipment and facilities to provide what is being procured.
- (b) Legal capacity to enter into a contract for procurement
- (c) Shall not be insolvent, in receivership, bankrupt or in the process of being wound up and is not the subject of legal proceedings relating to the foregoing.
- (d) Shall not be debarred from participating in public procurement.

2.26. Procuring entity's right to accept or reject any or all tenders

2.26.1 The Procuring entity reserves the right to accept or reject any tender, and to annul the tendering process and reject all tenders at any time prior to contract award, without thereby incurring any liability to the affected tenderer or tenderers or any obligation to inform the affected tenderer or tenderers of the grounds for the Procuring entity's action. If the Procuring entity determines that none of the tenders is responsive, the Procuring entity shall notify each tenderer who submitted a tender.

2.26.2 The procuring entity shall give prompt notice of the termination to the tenderers and on request give its reasons for termination within 14 days of receiving the request from any tenderer.

2.26.3 A tenderer who gives false information in the tender document about its qualification or who refuses to enter into a contract after notification of contract award shall be considered for debarment from participating in future public procurement.

2.27 Notification of Award

2.27.1 Prior to the expiration of the period of tender validity, the Procuring entity will notify the successful tenderer in writing that its tender has been accepted.

2.27.2 The notification of award will constitute the formation of the contract subject to the signing of the contract between the tenderer and the procuring entity pursuant to clause 2.29. Simultaneously the unsuccessful tenderers shall be notified that their tenders have been unsuccessful.

2.27.3 Upon the successful Tenderer's furnishing of the performance security pursuant to paragraph 2.30, the Procuring entity will promptly notify each unsuccessful Tenderer and will discharge its tender security, pursuant to paragraph 2.12

2.29 Signing of Contract

2.29.1 At the same time as the Procuring entity notifies the successful tenderer that its tender has been accepted, the procuring entity will simultaneously inform the other tenderers that their tenders have not been successful.

2.29.2 Within fourteen (14) days of receipt of the Contract Form, the successful tenderer shall sign and date the contract and return it to the Procuring entity.

2.29.3 The contract will be definitive upon its signature by the two parties.

2.29.4 The parties to the contract shall have it signed within 30 days from the date of notification of contract award unless there is an administrative review request.

2.30 Performance Security

2.30.1 The successful tenderer shall furnish the performance security in accordance with the Appendix to instructions to tenders, in a form acceptable to the Procuring entity.

2.30.2 Failure by the successful tenderer to comply with the requirement of paragraph 2.29 or paragraph 2.30.1 shall constitute sufficient grounds for the annulment of the award and forfeiture of the tender security, in which event the Procuring entity may make the award to the next lowest evaluated tender or call for new tenders.

2.31 Corrupt or Fraudulent Practices

2.31.1 The procuring entity requires that tenderers observe the highest standard of ethics during the procurement process and execution of contracts. A tenderer shall sign a declaration that he has not and will not be involved in corrupt or fraudulent practices.

2.31.2 The Procuring entity will reject a proposal for award if it determines that the tenderer recommended for award has engaged in corrupt or fraudulent practices in competing for the contract in question

2.31.3 Further a tenderer who is found to have indulged in corrupt or fraudulent practices risks being debarred from participating in public Procurement in Kenya.

APPENDIX TO INSTRUCTIONS TO TENDERERS

Notes to the Appendix to the Instructions to Tenderers

1. The Appendix to instructions to tenderers is intended to assist the procuring entity in providing specific information in relation to corresponding clauses in the Instructions to Tenderers included in Section II and has to be prepared for each specific procurement.
2. The procuring entity should specify in the appendix information and requirements specific to the circumstances of the procuring entity, the particulars of the tender, and the tender evaluation criteria that will apply to the tenders.
3. In preparing the Appendix the following aspects should be taken into consideration;
 - (a) The information that specifies and complements provisions of Section II to be incorporated.
 - (b) Amendments and/or supplements if any, to provisions of Section II as necessitated by the circumstances of the particulars of the tender to be also incorporated.
4. Section II should remain unchanged and can only be amended through the Appendix to Instructions to Tenderers.
5. Clauses to be included in this part must be consistent with the public procurement law and regulations.

Appendix to instructions to Tenderers

The following information for procurement of services shall complement or amend the provisions of the instructions to tenderers. Wherever there is a conflict between the provisions of the instructions to tenderers and the provisions of the appendix, the provisions of the appendix herein shall prevail over those of the instructions to tenderers

ITT Clause Number	Amendments and Supplements Clauses in the Instruction to Tenderers
2.1.1	All tenderers are eligible; Eligible Candidates
2.4.1	The address for requesting clarification is: The Principal Secretary The National Treasury Harambee Avenue 6TH floor, room 619 P.O.Box 30007, Nairobi Tel: +254 – 20 – 2252299
2.6.1	The Language of all correspondence and documents related to the Tender is: English
2.9.3	The prices shall be FIXED
	Alternative Tenders to the requirements of the Tender documents will Not be permitted
2.10.1	Prices shall be quoted in Kenya Shillings
2.12.2	The Tender Security shall be; - Bid Security of Kenya Shillings Five Hundred Thousand (Kshs. 500,000.00) from a Reputable Financial Institution valid for 30 days beyond Tender Validity
2.13.1	The Tender validity period shall be 150 days.
2.14.1	The number of copies of the Tender to be completed and returned shall be: One (1) original and Five (5) copies.
2.16.1	Tender shall be submitted to The Principal Secretary, The National Treasury Harambee Avenue 6TH floor, room 619 P.O. Box 30007, Nairobi The deadline for bid submission is: Date: 25th February, 2020 at 11.00 a.m.
2.18.1	The Tender opening shall take place at: The National Treasury Harambee Avenue, Nairobi – Kenya 6th Floor Conference Room, Date: 25th February, 2020 at 11.00 a.m.

2.20.1 **Preliminary Examination:**

The preliminary evaluation criteria will be as below: -

Mandatory requirements:

1. Certificate of Incorporation or Certificate of Registration
2. Valid current Tax Compliance Certificate
3. Duly filled, signed and stamped Confidential Business Questionnaire
4. Duly filled, signed and stamped Form of Tender
5. County Government Single Business Permit
6. Certificate of Confirmation of Directors and Shareholding (CR 12) (Issued within the last 12 Months to Tender Opening Date)
7. Bid Security of **Kenya Shillings Five Hundred Thousand (Kshs. 500,000.00)** from a Reputable Financial Institution valid for 30 days beyond Tender Validity.
8. Evidence having met International Data Centre Standards TIA -942 or any other recognized International standard for tier 3 Data centre.
9. Certificate of Registration from **Communication Authority of Kenya**
10. Certification from **Communication Authority of Kenya to operate Data Centre services.**
11. Certificate of attendance of Pre-Bid Meeting
12. Hosting and Co-Location **MUST** be done within Kenyan Border

AT THIS STAGE, THE TENDERER'S SUBMISSION WILL EITHER BE RESPONSIVE OR NON RESPONSIVE. THE NON RESPONSIVE SUBMISSIONS WILL BE ELIMINATED FROM THE ENTIRE EVALUATION PROCESS AND WILL NOT BE CONSIDERED FURTHER.

All Bidders MUST respond to LOT 1 and LOT 2

2.22.1 **Technical Evaluation criteria: LOT 1**

B	Technical requirements Compliance		
S/No	Criteria		Scores
1	General Experience of the firm a. Provide 4 orders / contracts in the Government / Public Sector with values of at least Ksh 50,000,000.00 performed in the past 2 years	Attach orders / contracts – 2 Marks each	8
2	Specific Experience of the firm relating to this tender Provide 4 relevant orders / contracts from different Government Ministry /	4 relevant orders with value of Ksh 1,000,000.00 per order <ul style="list-style-type: none"> o Relevant experience in Data Centre Colocation Service –(10 Marks) o Data Centre Technical Specifications & 	20

		Department or Public Sector with values of at least Ksh 5,000,000.00 each performed in the past 1-year in Data Centre Colocation Service and purpose-built certified data centre premises	Features for purpose-built certified datacentre premises – (10 Marks)	
	3	At least Three (3) completed Public Sector / Corporate Related projects undertaken	Attach 3 references letters/completion certificates)	6
	4	Detailed proposal on layout, methodology and set-up of the service		10
	5	Provide detailed project work plan	Attach Work plan with clear deliverables	10
		Qualifications and Competence of the key Staff for the assignment		
	6	Proof of staff capacity/ professional qualifications.	<p>One Project Manager</p> <ul style="list-style-type: none"> • Master’s Degree in Information Technology / Computer Science (1 mark) • At least 5 projects experience in managing cloud solutions and projects Project Manager (2 marks) • At least one professional qualification in project management e.g. PMP/Prince2 Certified (1 mark) <p>Systems /Infrastructure Engineers - (at least five)</p> <ul style="list-style-type: none"> • Bachelor’s Degree in Software Engineering/Software Development/ Business System Engineering/Technology / Computer Science or equivalent. (1 mark) • Should have at least 5 years of experience in design and support of applications in IaaS and PaaS environments (1 mark) • Should have at least five years in security implementation cloud solutions project experience in public sector or in financial sector • Should hold very strong understanding in design and implementation of business process solutions using standard methodologies (1 mark) 	23

			<ul style="list-style-type: none"> • Should hold application development and platform specific certifications (e.g. from Microsoft, Linux, CISCO and other open source environments) for at least 3 years (1 mark) <p>Database Administrators - (at least two)</p> <ul style="list-style-type: none"> • At least a Bachelor’s Degree in Information Technology / Computer Science or equivalent (1 mark) • Relevant certification Professional or equivalent (1 mark) • At least 4 years of Relevant database support or implementation experience (2 mark) <p>System Administrators (Operating system) - (at least two)</p> <ul style="list-style-type: none"> • At least a Bachelor’s Degree Information Technology / Computer Science or equivalent (1 mark) • At least one certification in (Microsoft/Solaris/Unix/Red-hut) (2 mark) • At least 3 years’ experience in systems administration in Microsoft/Solaris/Unix/Red-hut in compliance with Data Protection Act 2019(1 mark) <p>Information Security Engineers</p> <ul style="list-style-type: none"> • At least a Bachelor’s Degree Information Technology / Computer Science or equivalent (1 mark) • At least one certification in (Windows/Solaris/Unix/Red-hut) (1 mark) • At least 3 years’ experience System Administration (0.5 mark) • Vendor Certifications in Information Security (CISM, CCNP, CISSP) (1 mark) <p>Customer Support Specialists (3 specialists)</p> <ul style="list-style-type: none"> • Experience in customer services (2 marks) • Experience in Enterprise Architecture platforms (1 mark) 	
--	--	--	--	--

	7	Documentation and proposed Service Level Agreement	Attach proposed SLA	5
	8	Submit bank statement for the last 6 months with a cash balance of Kshs. 5,000,000.00 per month	1 Mark for each month	6
	9	Evidence of lines of Credit	Attach letter from the Bank on availability of Credit / Overdraft	3
	10	Financial Strength: Must demonstrate financial capability (Annual turnover Kshs.100,000,000.00 per year)	Attach Audited Accounts for the year 2018, 2017, 2016– 3 Marks each	6
	11	A tenderer has submitted a document which is well bound, serialized and has a table of contents.	Well Bound-(1mk), Serialized-(1mk) and Table of contents (1mk).	3
		Total		100
	NOTE: Only bidders who score 70% and above will be considered for financial evaluation. Those who score below 70% will be eliminated at this stage from the entire evaluation process and will not be considered further.			
2.24	Post – qualification shall “be undertaken” Yes			
2.25.1	Award Criteria: The lowest evaluated bidder			
	The maximum percentage by which quantities may be increased is: 25% The maximum percentage by which quantities may be decreased is: 25%			
2.30.1	Particulars of performance security if applicable.- 10% of the contract sum from a reputable financial institution			

SECTION III

GENERAL CONDITIONS OF CONTRACT

3.1 Definitions

3.1.1 In this Contract, the following terms shall be interpreted as indicated: -

- (a) “The Contract” means the agreement entered into between the Procuring entity and the tenderer, as recorded in the Contract Form signed by the parties, including all attachments and appendices thereto and all documents incorporated by reference therein.
- (b) “The Contract Price” means the price payable to the tenderer under the Contract for the full and proper performance of its contractual obligations
- (c) “The Goods” means all of the equipment, machinery, and/or other materials, which the tenderer is required to supply to the Procuring entity under the Contract.
- (d) “The Procuring entity” means the organization purchasing the Goods under this Contract.
- (e) “The Tenderer” means the individual or firm supplying the Goods under this Contract.

3.2 Application

3.2.1 These General Conditions shall apply in all Contracts made by the Procuring entity for the procurement installation and commissioning of equipment

3.3 Country of Origin

3.3.1 For purposes of this clause, “Origin” means the place where the Goods were mined, grown or produced.

3.3.2 The origin of Goods and Services is distinct from the nationality of the tenderer.

3.4 Standards

3.4.1 The Goods supplied under this Contract shall conform to the standards mentioned in the Technical Specifications.

3.5 Use of Contract Documents and Information

3.5.1 The tenderer shall not, without the Procuring entity’s prior written consent, disclose the Contract, or any provision therefore, or any specification, plan, drawing, pattern, sample, or information furnished by or on behalf of the Procuring entity in connection therewith, to any person other than a person employed by the tenderer in the performance of the Contract.

3.5.2 The tenderer shall not, without the Procuring entity’s prior written consent, make use of any document or information enumerated in paragraph 3.5.1 above

3.5.3 Any document, other than the Contract itself, enumerated in paragraph 3.5.1 shall remain the property of the Procuring entity and shall be returned (all copies) to the Procuring entity on completion of the Tenderer's performance under the Contract if so required by the Procuring entity

3.6 Patent Rights

3.6.1 The tenderer shall indemnify the Procuring entity against all third-party claims of infringement of patent, trademark, or industrial design rights arising from use of the Goods or any part thereof in the Procuring entity's country

3.7 Performance Security

3.7.1 Within thirty (30) days of receipt of the notification of Contract award, the successful tenderer shall furnish to the Procuring entity the performance security in the amount specified in Special Conditions of Contract.

3.7.2 The proceeds of the performance security shall be payable to the Procuring entity as compensation for any loss resulting from the Tenderer's failure to complete its obligations under the Contract.

3.7.3 The performance security shall be denominated in the currency of the Contract, or in a freely convertible currency acceptable to the Procuring entity and shall be in the form of a bank guarantee or an irrevocable letter of credit issued by a reputable bank located in Kenya or abroad, acceptable to the Procuring entity, in the form provided in the tender documents.

3.7.4 The performance security will be discharged by the Procuring entity and returned to the Candidate not later than thirty (30) days following the date of completion of the Tenderer's performance obligations under the Contract, including any warranty obligations, under the Contract

3.8 Inspection and Tests

3.8.1 The Procuring entity or its representative shall have the right to inspect and/or to test the goods to confirm their conformity to the Contract specifications. The Procuring entity shall notify the tenderer in writing in a timely manner, of the identity of any representatives retained for these purposes.

3.8.2 The inspections and tests may be conducted in the premises of the tenderer or its subcontractor(s), at point of delivery, and/or at the Goods' final destination. If conducted on the premises of the tenderer or its subcontractor(s), all reasonable facilities and assistance, including access to drawings and production data, shall be furnished to the inspectors at no charge to the Procuring entity.

3.8.3 Should any inspected or tested goods fail to conform to the Specifications, the Procuring entity may reject the equipment, and the tenderer shall either replace the rejected equipment or make alterations necessary to make specification requirements free of costs to the Procuring entity.

3.8.4 The Procuring entity's right to inspect, test and where necessary, reject the goods after the Goods' arrival shall in no way be limited or waived by reason of the equipment having previously been inspected, tested and passed by the Procuring entity or its representative prior to the equipment delivery.

3.8.5 Nothing in paragraph 3.8 shall in any way release the tenderer from any warranty or other obligations under this Contract.

3.9 Packing

3.9.1 The tenderer shall provide such packing of the Goods as is required to prevent their damage or deterioration during transit to their final destination, as indicated in the Contract.

3.9.2 The packing, marking, and documentation within and outside the packages shall comply strictly with such special requirements as shall be expressly provided for in the Contract

3.10 Delivery and Documents

3.10.1 Delivery of the Goods shall be made by the tenderer in accordance with the terms specified by Procuring entity in its Schedule of Requirements and the Special Conditions of Contract

3.11 Insurance

3.11.1 The Goods supplied under the Contract shall be fully insured against loss or damage incidental to manufacturer or acquisition, transportation, storage, and delivery in the manner specified in the Special conditions of contract.

3.12 Payment

3.12.1 The method and conditions of payment to be made to the tenderer under this Contract shall be specified in Special Conditions of Contract

3.12.2 Payments shall be made promptly by the Procuring entity as specified in the contract

3.13 Prices

3.13.1 Prices charged by the tenderer for goods delivered and services performed under the Contract shall not, with the exception of any price adjustments authorized in Special Conditions of Contract, vary from the prices by the tenderer in its tender.

3.13.2 Contract price variations shall not be allowed for contracts not exceeding one year (12 months)

3.13.3 Where contract price variation is allowed, the variation shall not exceed 10% of the original contract price.

3.13.4 Price variation request shall be processed by the procuring entity within 30 days of receiving the request.

3.14 Assignment

3.14.1 The tenderer shall not assign, in whole or in part, its obligations to perform under this Contract, except with the Procuring entity's prior written consent

3.15 Subcontracts

3.15.1 The tenderer shall notify the Procuring entity in writing of all subcontracts awarded under this Contract if not already specified in the tender. Such notification, in the original tender or later, shall not relieve the tenderer from any liability or obligation under the Contract

3.16 Termination for default

3.16.1 The Procuring entity may, without prejudice to any other remedy for breach of Contract, by written notice of default sent to the tenderer, terminate this Contract in whole or in part

- (a) if the tenderer fails to deliver any or all of the goods within the period(s) specified in the Contract, or within any extension thereof granted by the Procuring entity
- (b) if the tenderer fails to perform any other obligation(s) under the Contract
- (c) if the tenderer, in the judgment of the Procuring entity has engaged in corrupt or fraudulent practices in competing for or in executing the Contract

3.16.2 In the event the Procuring entity terminates the Contract in whole or in part, it may procure, upon such terms and in such manner as it deems appropriate, equipment similar to those undelivered, and the tenderer shall be liable to the Procuring entity for any excess costs for such similar goods.

3.17 Liquidated Damages

3.17.1. If the tenderer fails to deliver any or all of the goods within the period(s) specified in the contract, the procuring entity shall, without prejudice to its other remedies under the contract, deduct from the contract prices liquidated damages sum equivalent to 0.5% of the delivered price of the delayed items up to a maximum deduction of 10% of the delayed goods. After this the tenderer may consider termination of the contract.

3.18 Resolution of Disputes

3.18.1 The procuring entity and the tenderer shall make every effort to resolve amicably by direct informal negotiation and disagreement or dispute arising between them under or in connection with the contract

3.18.2 If, after thirty (30) days from the commencement of such informal negotiations both parties have been unable to resolve amicably a contract dispute, either party may require

adjudication in an agreed national or international forum, and/or international arbitration.

3.19 Language and Law

3.19.1 The language of the contract and the law governing the contract shall be English language and the Laws of Kenya respectively unless otherwise stated.

3.20 Force Majeure

3.20.1 The tenderer shall not be liable for forfeiture of its performance security or termination for default if and to the extent that its delay in performance or other failure to perform its obligations under the Contract is the result of an event of Force Majeure.

SECTION IV - SPECIAL CONDITIONS OF CONTRACT

Notes on Special Conditions of Contract

1. The clauses in this section are intended to assist the procuring entity in providing contract-specific information in relation to corresponding clauses in the General Conditions of Contract
2. The Provisions of Section IV complement the General Conditions of Contract included in Section III, specifying contractual requirements linked to the special circumstances of the procuring entity and the particulars of the tender. In preparing Section IV, the following aspects should be taken into consideration.
 - (a) Information that complement provisions of Section III must be incorporated; and
 - (b) Amendments and/or supplements to provisions of Section III, as necessitated by the circumstances of the particulars of the tender must also be incorporated.
3. Section III should remain unchanged and can only be amended through the SCC Section IV.
4. Clauses to be included in this part must be consistent with the public procurement law and the regulations.

SECTION IV SPECIAL CONDITIONS OF CONTRACT

- 4.1 Special conditions of contract shall supplement the general conditions of contract, wherever there is a conflict between the GCC and the SCC, the provisions of the SCC herein shall prevail over those in the GCC.
- 4.2 Special conditions of contract with reference to the general conditions of contract.

General conditions of contract reference	Special conditions of contract
3.7	Specify performance security if applicable: 10% of the contract sum from a reputable financial institution
3.8	Payments shall be made by The National Treasury as follows: - 1. Installation and set-up cost: -This shall be after successful set-up and inspection by The National Treasury Inspection team 2. Subscription Services: This shall be paid quarterly in arrears
3.9	Specify price adjustments allowed. None
3.14	Specify resolution of disputes: Arbitration
3.17	Specify applicable law. Laws of Kenya
3.18	Notices shall be addressed and delivered to: The Principal Secretary The National Treasury Treasury Building, Harambee Avenue P.O. Box 30007 – 00100 Nairobi

Other conditions

- The prices quoted should be valid for a period of **Three (3 No.) Years**.

SECTION V - SCHEDULE OF REQUIREMENTS

BACKGROUND INFORMATION

The Government Digital Payments Unit is a Unit under the Directorate of Accounting Services and Quality Assurance of the National Treasury. As per the Gazette No. 400 of 12th January 2018, the Unit reports to a Steering Committee which is chaired by the PS/National Treasury. The Unit mandate is to digitize all payments into Government with an aim to increase revenue collection, minimize the cost of collection and enhance service delivery. Since its inception in 2014, over 18 Million applications have been processed and over Kshs 60 Billion have been collected through the online portal, www.ecitizen.go.ke which is managed by the GDP Unit.

The benefits available to government from digitization of payments in terms of economic growth, increased government revenues and efficiency savings, serve as a call to action by the Government of Kenya to drive development of electronic payment systems. Globally, digitization is known to help agencies progress faster towards their policy goals free from the maze of bureaucracy. It is on this strength that the Government of Kenya is embarking on a number of reforms to increase its operational efficiency, grow revenues and transform service delivery within the public sector. Government Digital Payments Programme is one such reform being implemented by the Kenyan Government.

To address these loopholes, His Excellency The President gave a directive in November 2013 that all payments into government shall be digital. This culminated to the formation of cabinet committee chaired by His Excellency The Deputy President to guide the Government Digital Payments process and establishment of a Taskforce and a Taskforce Secretariat vide Gazette Notice No 2725 of April 24, 2014. The eCitizen portal, www.eCitizen.go.ke was thereafter developed as a payment gateway through which citizens and all persons would pay for government services. The portal was integrated with electronic payment platforms including mobile telephone money payment services. This portal was entrenched in a Gazette Notice No. 9290 of 30th December 2014.

The mandate of the Taskforce was later enhanced through a Gazette Notice no. 3299 of 13th May 2015. The Programme is now championed by the Government Digital Payments (GDP) Unit under the Directorate of Accounting Services and Quality Assurance and reports to a

Steering Committee chaired by the PS/National Treasury which was created through a Gazette Notice No. 400 dated 12th January 2018.

PROJECT BACKGROUND

Government Digital Payment (GDP), through National Treasury intends to enhance the capabilities and scope of the platform, so that more services can be digitized onto the eCitizen platform. The enhancement and increase in scope will require that GDP engages the services and expertise of application developers and system integrators.

Currently, the eCitizen platform consists of gateway for digital government services and payments. It is composed of a Single Sign-on component, a payment aggregation and settlement component and an application submission and processing component. The application component integrates with the single-Sign-on and payment layers via standard interfaces.

PROJECT GOALS AND SCOPE OF SERVICES

The scope of the project is to engage system developers and integrators in providing support for the existing systems, enhance and update them as required and onboard additional services into the digital payments framework.

The tasks and deliverables include the following:

- Maintain the current eCitizen infrastructure
- Provide second level support to MDA's and other client facing support staff on account, payments and other related issues
- Fix bugs and add features as may be required to the existing eCitizen infrastructure
- On-board additional agencies and services onto the Ecitizen ecosystem/platform
- Strictly adhere to the provisions of and compliance with Data Protection Act 2019
- Skills transfer Plan for at least twelve (12) officers drawn from Management, ICT and internal Audit.

GENERAL OBJECTIVES OF THE ASSIGNMENT

The following are the main objectives of the service.

1. Provide a Tier 3 or above colocation facility.
2. To safeguard mission-critical data and systems with the highest levels of security and operational reliability and to ensure Business continuity.

3. Provide rack space with, network switches, network connections, cable organizers, power distribution Units, redundant internal network distribution platforms to Ecitizen's systems.
4. Provide Industry Standard Environmental and Power Controls to Ecitizen's systems to guarantee optimal functionality.
5. Provide Physical, Surveillance and access control system to Ecitizen's Systems to ensure security.
6. Provide 24 x 7 on-site hands-on support services.

SCOPE AND DELIVERABLES OF THE ASSIGNMENT - LOT 2:

The Service provider shall: -

- 1) Provide the following services; Data Centre as a service, Storage as a service, back-up as a service, Archiving as a service and Disaster recovery as a service
- 2) Provide a 20 (how many are we currently using?) U Rack space within its data centre white space. The racks shall be powered with sufficient clean power, cable organizers, power distribution units with separate power and data trunks. All power feed must be protected from brownout, spike and surges.
- 3) Provide dedicated fibre link from its datacentre to specific (how will this be quantified) Ministries, Counties, Departments and Agencies (MCDAs) dealing with and connected to Ecitizen platform
- 4) Provide structured cabling on the allocated Rack with proper labelling to all Equipment and cables.
- 5) Provide a resilient and fault tolerant power and cooling infrastructure so that the equipment will maintain operations within the manufacturer power, cooling and humidity parameters.
- 6) The Service Provider will monitor the co-located servers for the National Treasury and provide instant notifications and monthly reports on availability, outage and any errors on the physical systems
- 7) Provide Physical, Surveillance and access control system to Ecitizen's Systems with controlled, logged and visually monitored access, allowed only to personnel explicitly authorized by Government Digital Payments (GDP) Unit. Any security breaches including break-in to data centre, racks, or un-authorized access should be notified to GDP Unit within 15 minutes.
- 8) The Data Centre facility shall be protected by gas-based fire detection and suppression systems.
- 9) The Data Centre facility shall have Temperature, humidity and static control systems with Remote environmental alarms.
- 10) All scheduled maintenance periods that have the potential to disrupt Ecitizen services shall be notified at least Three (3) days in advance, and for major service interruption at least Two (2) weeks prior notice is needed.

- 11) Sign and abide with requirements for Non-Disclosure Agreement (NDA) with The National Treasury.
- 12) The bidders are expected to provide a schedule of deliverables.
- 13) Set up and installations at the Co-location environment should NOT go beyond 3 month after which the support contract will be signed.

APPLICATIONS AND INFRASTRUCTURE ARCHITECTURE OF THE ECITIZEN PLATFORM

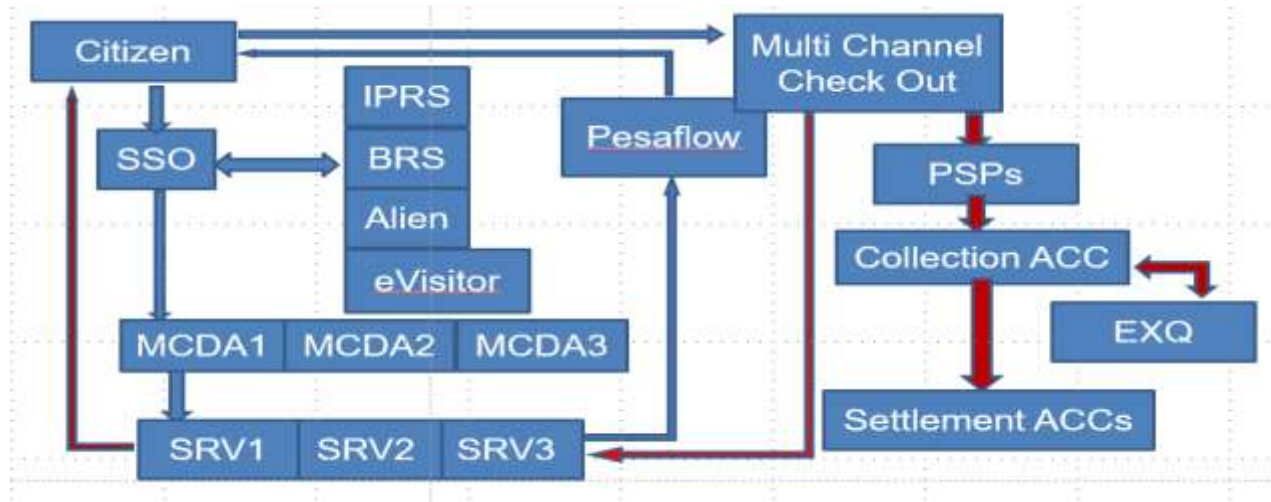

LEGEND:

- SSO = Single Sign-On
- IPRS = Integrated Population Registration Service
- PSP = Payment Service Provider
- BRS = Business Registration Services
- MCDA = Ministry, County, Department and Agency
- SRV = Server

DURATION OF THE ASSIGNMENT

The assignment will run for a period of 3 years

SECTION VI STANDARD FORMS

Notes on the sample Forms

1. **Form of Tender** -The form of Tender must be completed by the tenderer and submitted with the tender documents. It must also be duly signed by duly authorized representatives of the tenderer.
2. **Price Schedule Form**-The price schedule form must similarly be completed and submitted with the tender.
3. **Contract Form** - The contract form shall not be completed by the tenderer at the time of submitting the tender. The contract form shall be completed after contract award and should incorporate the accepted contract price.
4. **Confidential Business Questionnaire Form** - This form must be completed by the tenderer and submitted with the tender documents.
5. **Tender Security Form**-When required by the tender documents the tenderer shall provide the tender security either in the form included herein or in another format acceptable to the procuring entity. The tender security form must be completed by the tender and submitted with the tender.
6. **Performance security Form**-The performance security form should not be completed by the tenderers at the time of tender preparation. Only the successful tenderer will be required to provide performance security in the form provided herein or in another form acceptable to the procuring entity.
7. **Authorization Form** -When required by the tender documents this form must be completed and submitted with the tender documents. This form will be completed by the principal where the tenderer is an agent.

7.1 FORM OF TENDER

Date _____
Tender No. _____

To: _____

[name and address of procuring entity]

Gentlemen and/or Ladies:

1. Having examined the tender documents including Addenda Nos. *[Insert numbers]*, the receipt of which is hereby duly acknowledged, we, the undersigned, offer to supply deliver, install and commission *(Insert equipment description)* in conformity with the said tender documents for the sum of *(total tender amount in words and figures)* or such other sums as may be ascertained in accordance with the Schedule of Prices attached herewith and made part of this Tender.

2. We undertake, if our Tender is accepted, to deliver install and commission the equipment in accordance with the delivery schedule specified in the Schedule of Requirements.

3. If our Tender is accepted, we will obtain the guarantee of a bank in a sum of equivalent to _____ percent of the Contract Price for the due performance of the Contract , in the form prescribed by *(Procuring entity)*.

4. We agree to abide by this Tender for a period of *[number]* days from the date fixed for tender opening of the Instructions to tenderers, and it shall remain binding upon us and may be accepted at any time before the expiration of that period.

5. This Tender, together with your written acceptance thereof and your notification of award, shall constitute a Contract, between us. Subject to signing of the Contract by the parties.

6. We understand that you are not bound to accept the lowest or any tender that you may receive.

Dated this _____ day of _____ 20 _____

[signature]

[in the capacity of]

Duly authorized to sign tender for an on behalf of _____

7.2 CONTRACT FORM

THIS AGREEMENT made the _____ day of _____ 20_____ between [name of Procurement entity] of _____ [country of Procurement entity] (hereinafter called “the Procuring entity”) of the one part and _____ [name of tenderer] of _____ [city and country of tenderer] (hereinafter called “the tenderer”) of the other part:

WHEREAS the Procuring entity invited tenders for the GPA cover and has accepted a tender by the tenderer for the supply of the services in the sum of _____ [contract price in words in figures] (hereinafter called “the Contract Price”).

NOW THIS AGREEMENT WITNESSTH AS FOLLOWS:-

1. In this Agreement words and expressions shall have the same meanings as are respectively assigned to them in the Conditions of Contract referred to.
2. The following documents shall be deemed to form and be read and construed as part of this Agreement, viz:
 - (a) the Tender Form and the Price Schedule submitted by the tenderer;
 - (b) the Schedule of Requirements
 - (c) the Details of cover
 - (d) the General Conditions of Contract
 - (e) the Special Conditions of Contract; and
 - (f) the Procuring entity’s Notification of Award
3. In consideration of the payments to be made by the Procuring entity to the tenderer as hereinafter mentioned, the tenderer hereby covenants with the Procuring entity to provide the GPA cover and to remedy defects therein in conformity in all respects with the provisions of the Contract.
4. The Procuring entity hereby covenants to pay the tenderer in consideration of the provision of the services and the remedying of defects therein, the Contract Price or such other sum as may become payable under the provisions of the contract at the times and in the manner prescribed by the contract.

IN WITNESS whereof the parties hereto have caused this Agreement to be executed in accordance with their respective laws the day and year first above written

Signed, sealed, delivered by _____ the _____ (for the Procuring entity)

Signed, sealed, delivered by _____ the _____ (for the tenderer) in the presence of _____

7.3 CONFIDENTIAL BUSINESS QUESTIONNAIRE FORM

You are requested to give the particulars indicated in Part 1 and either Part 2(a), 2(b) or 2 (c) whichever applied to your type of business

You are advised that it is a serious offence to give false information on this form

Part 1 – General:

Business Name
 Location of business premises.
 Plot No..... Street/Road
 Postal Address Tel No. Fax E mail
 Nature of Business
 Registration Certificate No.
 Maximum value of business which you can handle at any one time – Kshs.
 Name of your bankers Branch

Part 2 (a) – Sole Proprietor

Your name in full Age
 Nationality Country of origin
 • Citizenship details

Part 2 (b) Partnership

Given details of partners as follows:

Name	Nationality	Citizenship Details	Shares
1.
2.
3.
4.

Part 2 (c) – Registered Company

Private or Public

State the nominal and issued capital of company-

Nominal Kshs.

Issued Kshs.

Given details of all directors as follows

Name	Nationality	Citizenship Details	Shares
1.....
2.
3.
4.
5

Date Seal/Signature of Candidate

7.4 PRICE SCHEDULE FORM

A: INITIAL SETUP COST

No.	DESCRIPTION	PRICE (KSH)
1.	Set up and Installation cost.	

B: CLOUD PRICING PER MONTH (INCLUSIVE OF VAT)

S/NO	ITEM DESCRIPTION	UNIT OF MEASURE	UNIT PRICE	ESTIMATED QUANTITY	TOTAL
1.	CPU	(at least 2.1Ghz)		500	
2.	RAM	GB		1200	
3.	Storage	GB		100,000	
4.	Cloud Internet	MBPS		400	
5.	Internet Link	MBPS		50	
6.	MPLS	MBPS		30	
GRAND TOTAL					

We undertake, if our Tender is accepted to provide services in accordance with the schedule rates and delivery dates specified above.

Name

Name of signatory:

In the capacity of:

Authorized Signature:

Company Rubber Stamp/Seal.....

Prices should be inclusive of 16% VAT

7.5 TENDER SECURITY FORM

Whereas [*name of the tenderer*]
(hereinafter called “the tenderer”) has submitted its tender dated
[*date of submission of tender*] for the supply, installation and commissioning
of [*name and/or description of the equipment*]
(hereinafter called “the Tender”)
KNOW ALL PEOPLE by these presents that WE
..... of having our registered
office at (hereinafter called “the Bank”), are bound unto
..... [*name of Procuring entity*] (hereinafter called “the Procuring
entity”) in the sum of for which payment well
and truly to be made to the said Procuring entity, the Bank binds itself, its
successors, and assigns by these presents. Sealed with the Common Seal of the
said Bank this _____ day of _____ 20 _____.

THE CONDITIONS of this obligation are:-

1. If the tenderer withdraws its Tender during the period of tender validity specified by the tenderer on the Tender Form; or
2. If the tenderer, having been notified of the acceptance of its Tender by the Procuring entity during the period of tender validity:
 - (a) fails or refuses to execute the Contract Form, if required; or
 - (b) fails or refuses to furnish the performance security in accordance with the Instructions to tenderers;

We undertake to pay to the Procuring entity up to the above amount upon receipt of its first written demand, without the Procuring entity having to substantiate its demand, provided that in its demand the Procuring entity will note that the amount claimed by it is due to it, owing to the occurrence of one or both of the two conditions, specifying the occurred condition or conditions.

This tender guarantee will remain in force up to and including thirty (30) days after the period of tender validity, and any demand in respect thereof should reach the Bank not later than the above date.

[*signature of the bank*]

7.6 TENDER SECURING DECLARATION

[The Bidder shall fill in this Form in accordance with the instructions indicated.]

Date: *[insert date (as day, month and year) of Bid Submission]*

Tender No.: *[insert number of bidding process]*

To: *[insert complete name of Purchaser]*

We, the undersigned, declare that:

1. We understand that, according to your conditions, bids must be supported by a Tender-Securing Declaration.
2. We accept that we will automatically be suspended from being eligible for tendering in any public procurement tenders with any public entity for the period of time determined by the Public Procurement Oversight Authority, if we are in breach of our obligation(s) under the tendering conditions, because we:
 - a) have withdrawn our tender during the period of tender validity specified in the Tender Data Sheet; or
 - b) having been notified of the acceptance of our Tender by the Procuring Entity during the period of tender validity fail or refuse to execute the contract; or fail or refuse to furnish the performance security, if so required.
3. We understand that this Tender Securing Declaration shall expire if we are not the successful Tenderer, upon our receipt of your notification or regret of the tender award letter; or thirty-eight days after the expiration of our Tender, whichever is earlier.
4. We understand that if we are a Joint Venture, the Tender Securing Declaration must be in the name of the Joint Venture that submits the bid, and if the Joint Venture has not been legally constituted at the time of tendering, the Tender Securing Declaration shall be in the names of all envisaged partners as named in the letter of intent.

Signed: *[insert signature of person whose name and capacity are shown]* In the capacity of *[insert legal capacity of person signing the Tender Securing Declaration]*

Name: *[insert complete name of person signing the Tender Securing Declaration]*

Duly authorized to sign the bid for and on behalf of: *[insert complete name of Bidder]*

Dated on _____ day of _____, _____ *[insert date of signing]*

7.7 PERFORMANCE SECURITY FORM

To
[name of Procuring entity]

WHEREAS [name of tenderer] (hereinafter called “the tenderer”) has undertaken , in pursuance of Contract No. _____ [reference number of the contract] dated _____ 20 _____ to supply [description of goods] (hereinafter called “the Contract”).

AND WHEREAS it has been stipulated by you in the said Contract that the tenderer shall furnish you with a bank guarantee by a reputable bank for the sum specified therein as security for compliance with the Tenderer’s performance obligations in accordance with the Contract.

AND WHEREAS we have agreed to give the tenderer a guarantee:

THEREFORE WE hereby affirm that we are Guarantors and responsible to you, on behalf of the tenderer, up to a total of [amount of the guarantee in words and figure] and we undertake to pay you, upon your first written demand declaring the tenderer to be in default under the Contract and without cavil or argument, any sum or sums within the limits of [amount of guarantee] as aforesaid, without you needing to prove or to show grounds or reasons for your demand or the sum specified therein.

This guarantee is valid until the _____ day of _____ 20 _____

Signed and seal of the Guarantors

[name of bank or financial institution]

[address]

[date]

7.8 MANUFACTURERS AUTHORIZATION FORM

To *[name of the Procuring entity]*

WHEREAS

[Name of the principal]

who are established and reputation dealers in *[Type of business]*
having registered offices at *[Address of principal]* do hereby authorizing *[Name and address of tenderer]* to submit a tender, *[reference of the tender]* for the stated (*particulars of tender*).

We hereby extend our full guarantee and warranty as per the General Conditions of Contract for the services to be provided against this Invitation for Tenders.

[Signature for and on behalf of the principal]

Note: This letter of authority should be on the letterhead of the principal and should be signed by a competent person.

7.9 LETTER OF ACCEPTANCE/NOTIFICATION OF AWARD

[to be printed on the Letterhead of the Procuring Entity]

[date]

To: *[name and address of the Supplier]*

Re: **Letter of Acceptance/Notification of Award**

This is to notify you that your Tender dated *[date]* for execution of the *[name of the Contract and identification number, as given in the Contract Data Sheet]* for the Contract Price of the equivalent of *[amount in numbers and words] [name of currency]*, as corrected and modified in accordance with the Instructions to Tenderers is hereby accepted by us and it is our intention to proceed to make a written contract in accordance with the terms specified in the tender documents on the expiry of fourteen (14) days period from the date of this notification.

The contract shall be signed by the parties within 30 days from the date of this letter but not earlier than 14 days from the date of the letter.

Yours

(Name of Accounting Officer)
Accounting Officer/Head of Procuring Entity

Please return a copy of this letter duly signed

Authorized Signature and Seal: _____

Name and Title of Signatory: _____

Name of Tenderers: _____

7.10 FORM RB 1

REPUBLIC OF KENYA
PUBLIC PROCUREMENT ADMINISTRATIVE REVIEW BOARD

APPLICATION NO.....OF.....20.....

BETWEEN

.....APPLICANT

AND

.....RESPONDENT (*Procuring Entity*)

Request for review of the decision of the..... (*Name of the Procuring Entity*) of
.....dated the...day of20.....in the matter of Tender No.....of
.....20...

REQUEST FOR REVIEW

I/We.....,the above named Applicant(s), of address: Physical
address.....Fax No.....Tel. No.....Email, hereby request the Public
Procurement Administrative Review Board to review the whole/part of the above
mentioned decision on the following grounds , namely:-

- 1.
 - 2.
- etc.

By this memorandum, the Applicant requests the Board for an order/orders that: -

- 1.
 - 2.
- etc

SIGNED (Applicant)

Dated on.....day of/...20...

FOR OFFICIAL USE ONLY

Lodged with the Secretary Public Procurement Administrative Review Board on day of
.....20.....

SIGNED
Board Secretary